





Table of contents

- › Company
- › Generational changeover
- › Mission vision value and claim
- › People
- › The market and Lanulfi strategic positions
- › Product thermoplastic:
 - Compression
 - Injection
 - Vacuum forming
 - Rotomoulding
- › Product thermosetting:
 - Thermosetting aluminum tools
 - Thermosetting steel tools
- › Models and prototypes
- › Special equipments
- › Strategic goals 2024/2026
- › Equipment list



Start of business



First CNC machine and first CAD software



New headquarters 3000 m²



Beginning of exportation



1981

1993

2000

2007

2018

2019

2020

2023



Lanulfi 4.0



Group of firms



Robot sanding



First Business Plan



Divisions Lanulfi

Lanulfi is a company operating in various technologies and with 3 divisions by business area.



Aluminum mould making



Constructions of models and jigs



Steel mould making





Generational changeover



Moulds & People





Mission & Vision

LANULFI has been a leader and a **reliable partner** in the moulds sector since **1981**, paying great attention to its clients' needs and requests, to the **flexibility** and reliability of the solutions proposed, along with a constant drive to **innovation** through the **active engagement** of its people and the **well-established relationship** with clients and suppliers.

We aim to be the reference partner, offering **sustainable, reliable and concrete solutions**.

By sharing our **values**, we aim to create a constructive experience that will be the beginning of a better **future** together.

Values

TRUST

RESPECT

LISTENING

COHERENCE

CONSISTENCY

Claim

Moulds & **People**



People | Management



**Ferdinando
Lanulfi**

I am an
inexhaustible
source of ideas, art
is in my hands



Lino Lanulfi

Every morning the
sun rises for new
opportunities



Elisa Lanulfi

Elisa-I love being in
the middle of
nature.



Arrigo Lanulfi

Father of Ginevra, I
love flying but with
rationality



Marco Lanulfi

A constantly
evolving curious
mind, passionate
about "if not now
when?"



People



Claudio

Claudio, I am a lover of curves



Nicola

The security of my family, the company of trusted friends, a good glass of wine in hand, these are the ingredients of my happiness!



Davide

I love the mountains that fit me like a glove



Martina

Martina, I love long walks in the mountains--the best view comes after the most difficult climb!



Giovanni

John, my passion is sailing.



Martina

Martina, I love reading, traveling and nature



Andrea

I'm Andrea, I love to travel and I'm passionate about motorcycles



Enrico

Henry, the creative



Manuel

Work and commitment always pay off



Stefano

Berici Hills, Dolomites and cycling are my passions



Upananda

An icon of resilience and inner strength



Brigita

The human mind is full of extraordinary potential.



Simone

I find joy in the little things



Donato

..What an effort I ask of you...



Loris

A man's strength lies in rising up despite life's difficulties



Cristian

Every day an opportunity



Marco

In the mountains on a motorcycle with friends great sense of freedom



Marco

Marco, passionate about sports, music and traveling across borders.



Davide

A kind heart that loves to help others



Roberto

I love riding motorcycles and being a grandfather





People



Amos

I am happy with my work and a lover of good food



Matteo

I love nature and adventure



Massimo

An individual who strives for a better world



Matteo

A dreamer who is not afraid to pursue his dreams



Giancarlo

Giancarlo, proud grandfather 😊



Andrea F

Living each day with new stimulation and passion for what you do



Nicholas M

Living the present, dreaming the future, learning from the past.



Andrea M

If you don't like something, change it. If you cannot change it, change your attitude. Don't complain



People



Manuel

Manuel, dedicated to discipline and training



Luca

An eternal optimist who always sees the glass as half full



Amadou

An adventurer of the mind, always ready to learn



Ion

Ion, motor enthusiast and love hiking in the mountains



Agron

I'm Agron, I like to work



Milan

A dreamer who follows his heart



Stefano

Stephen, mountain and technology enthusiast



Laura

Laura, I like to draw and have a passion for plants and art



Taulant

Tireless worker with a passion for mechanics



Gianluca

I believe in the importance of family



Manjinder

I always see the bright side of life



Said

Loyal and ever-present friend



Target market

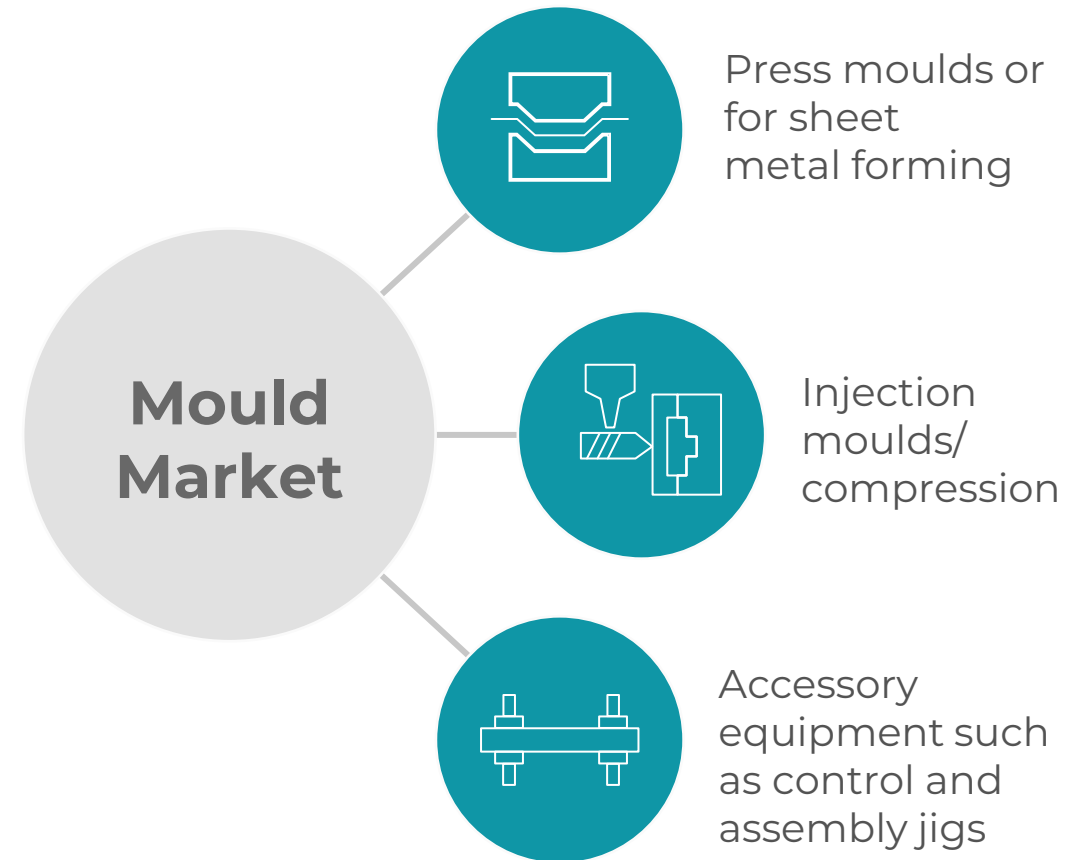
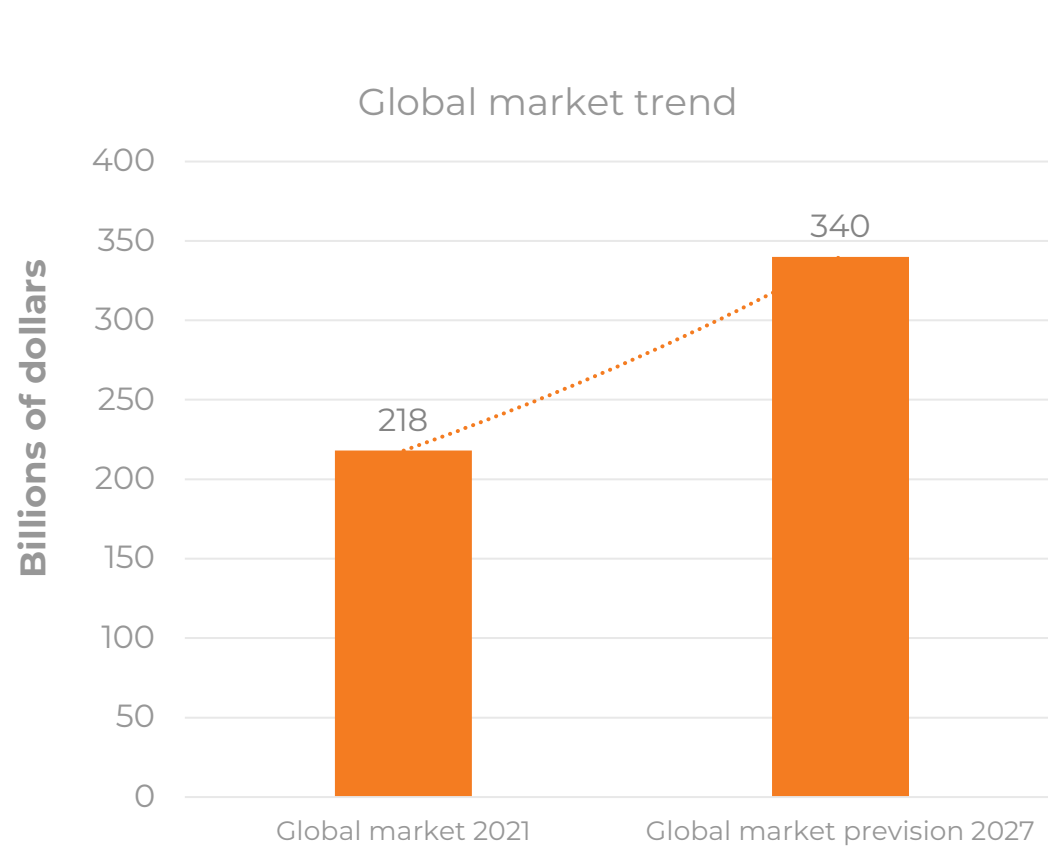



Target market

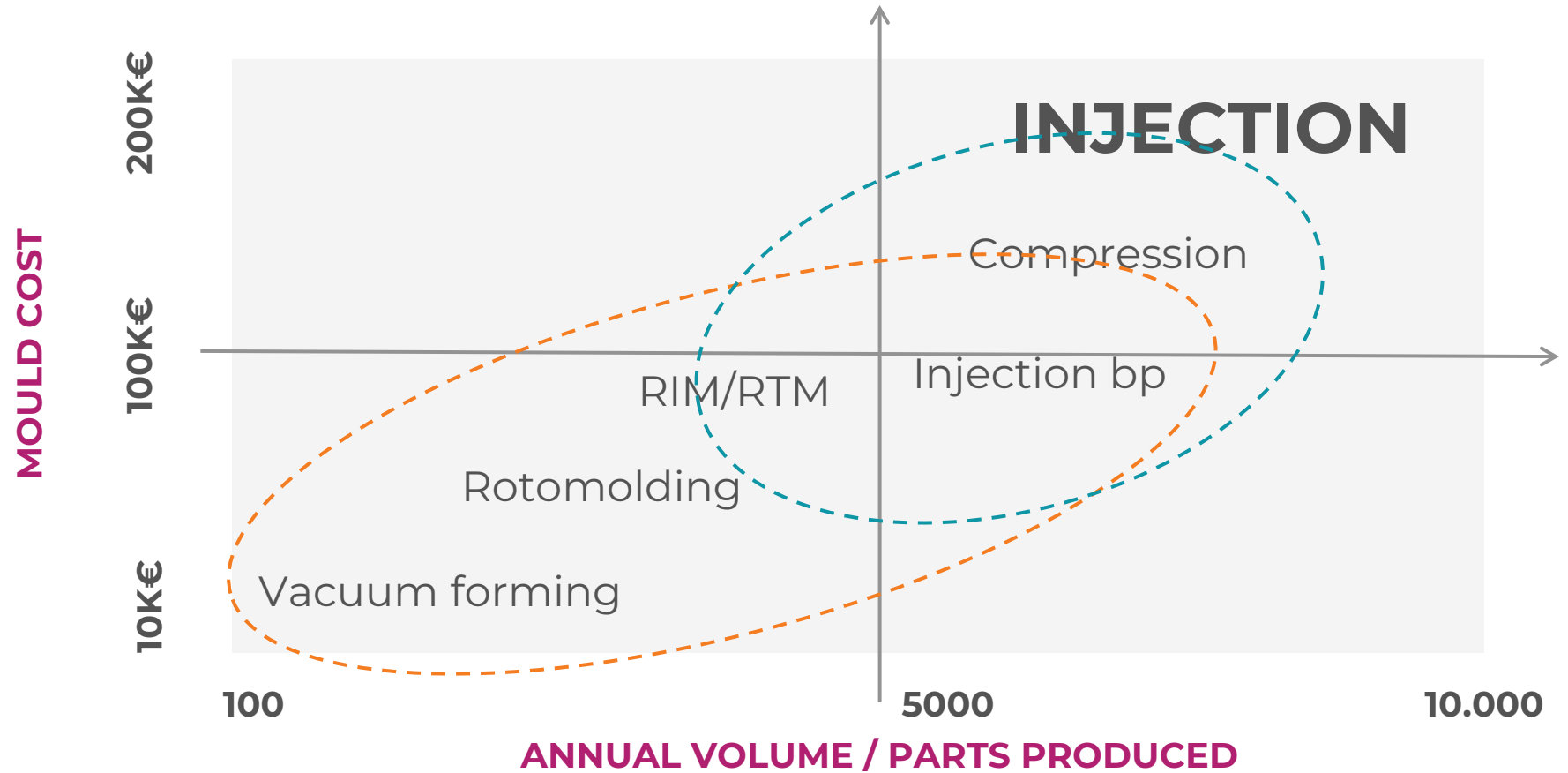



Target market

Injection/compression
moulds



THERMOPLASTICS

- Injections
- Low pressure injections
- Vacuum forming
- Rotomolding
- Compression (DLFT-GMT)

DIECASTING

THERMOSETTING

- Injection RIM/RTM
- Compression SMC / BMC



Automotive



Agriculture



Truck



Bus



Design and
products



Wellness and SPA



Product Value Trend

Product value trend from 2019 to 2023

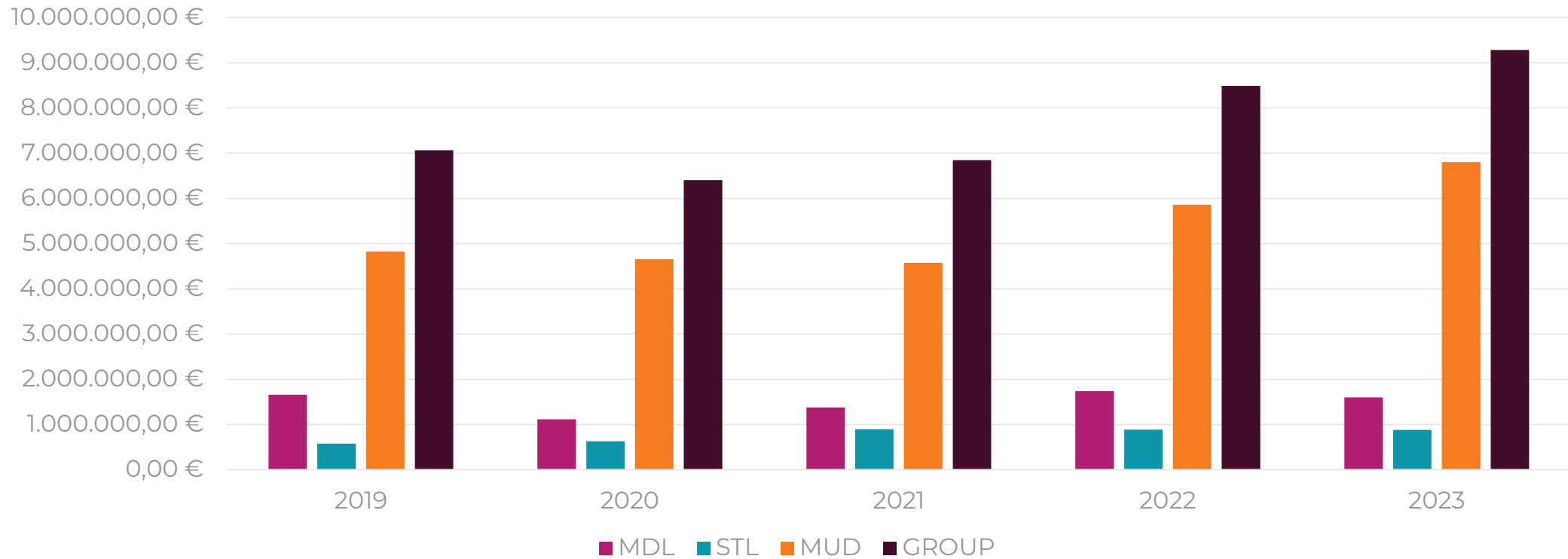



UNDER ENGINE COVER



COMPRESSION
THERMOPLASTICS



Automotive



Agriculture



Truck



Bus



Design and
products



Wellness and SPA



TRANSPORT PALLET

INJECTION

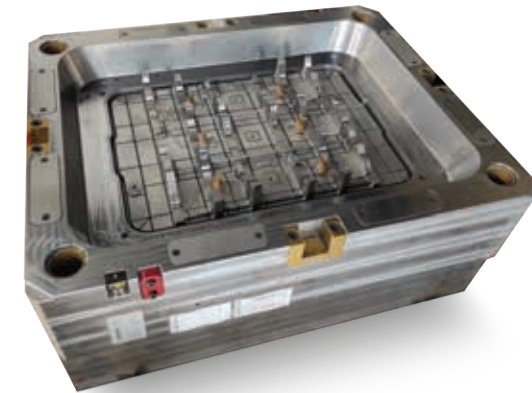
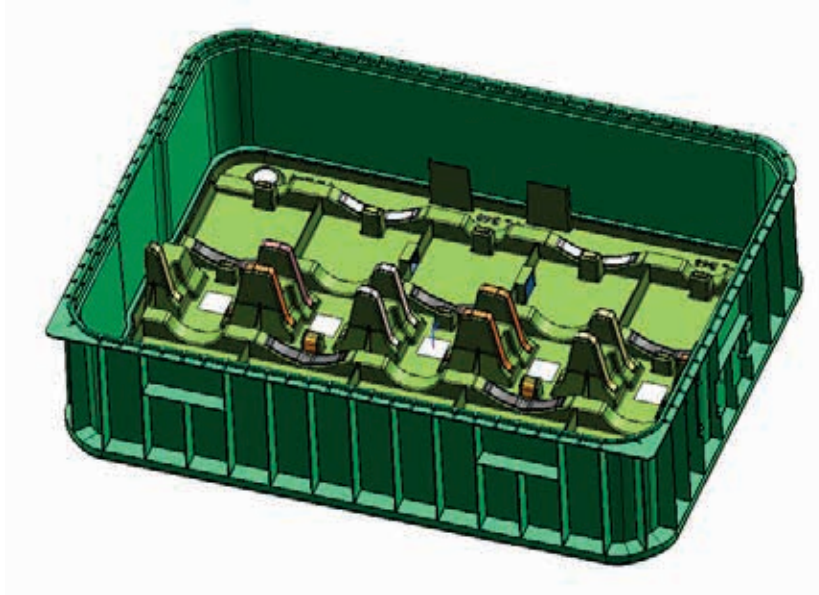

Automotive



Agriculture



Truck



Bus



Design and products



Wellness and SPA



BULK HEAD

INJECTION



Automotive



Agriculture



Truck



Bus



Design and products



Wellness and SPA



MOTOR BIKE COVER

INJECTION

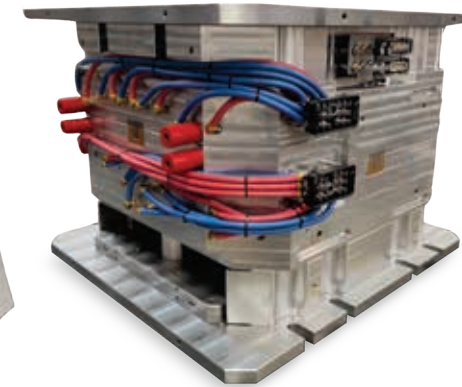
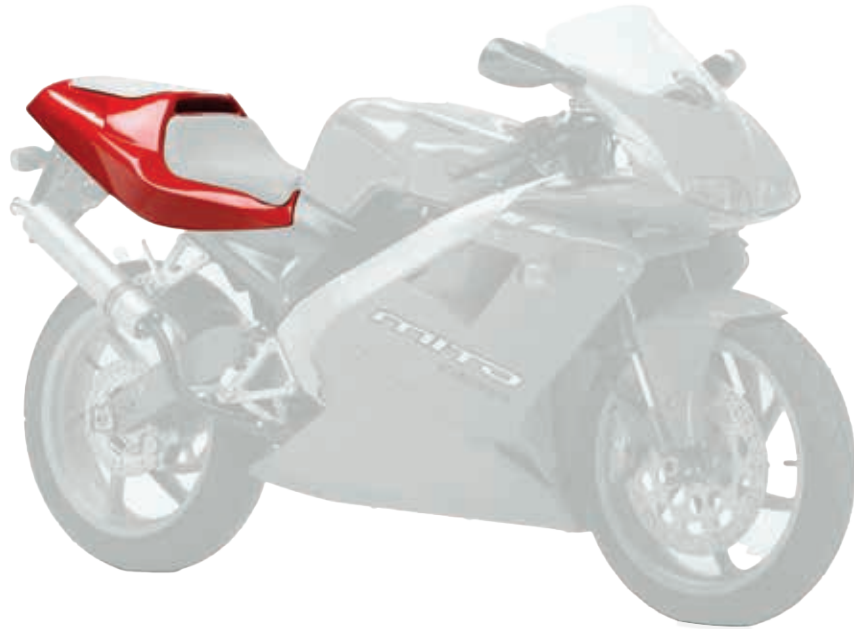

Automotive



Agriculture



Truck



Bus



Design and products



Wellness and SPA



MOTOR BIKE COVER

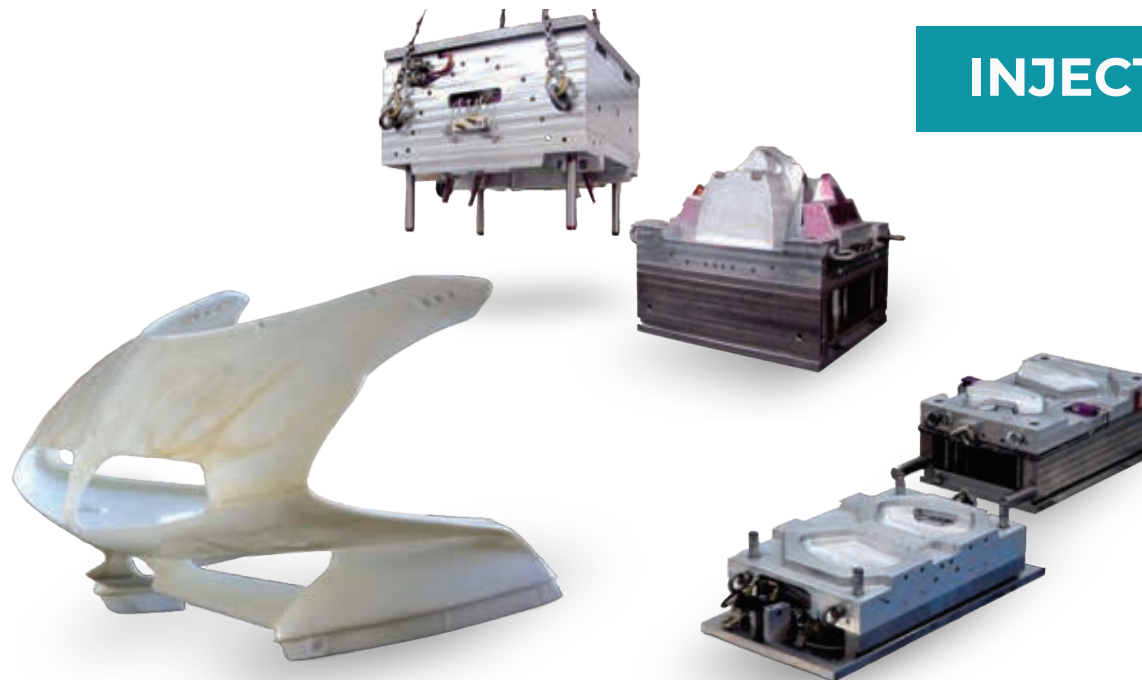

INJECTION



Automotive



Agriculture



Truck



Bus



Design and products



Wellness and SPA



AUTOMOTIVE SPOILER

INJECTION

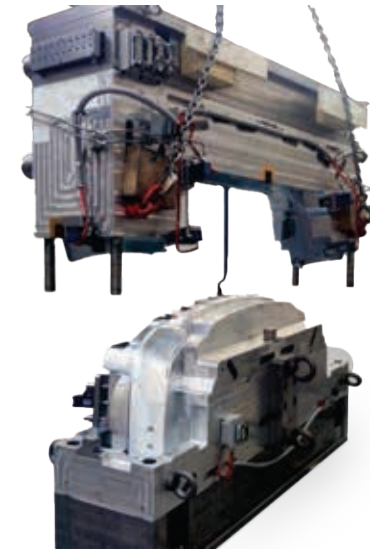
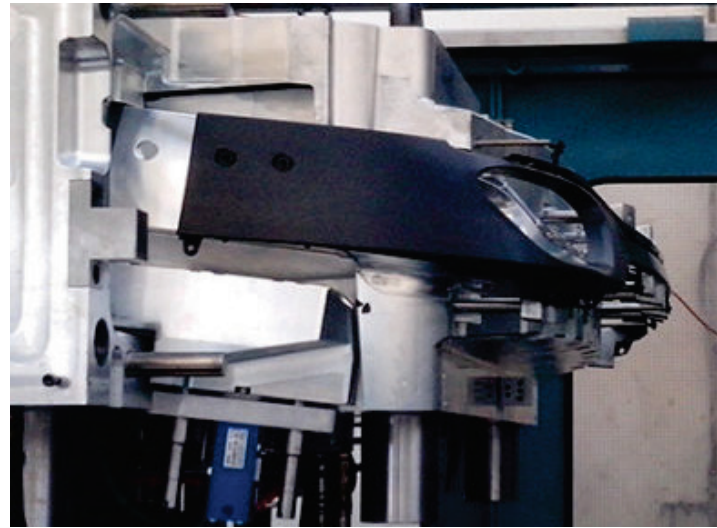

Automotive



Agriculture



Truck



Bus



Design and products



Wellness and SPA



CHROME FRONT GRILL



INJECTION

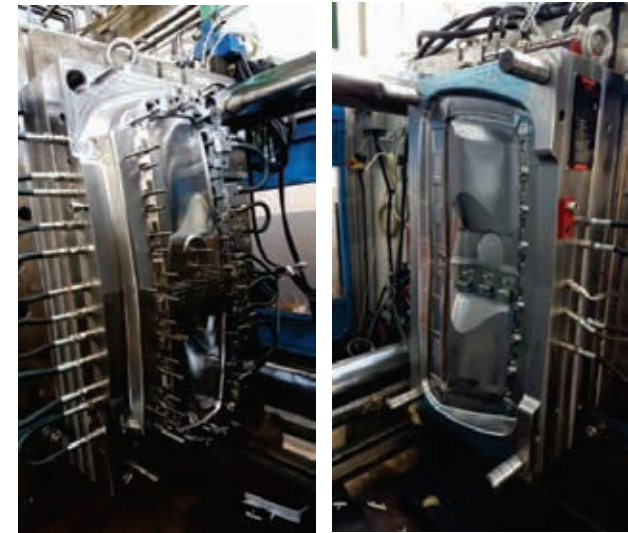

Automotive



Agriculture



Truck



Bus



Design and products



Wellness and SPA



CABIN AIR DUCT

INJECTION

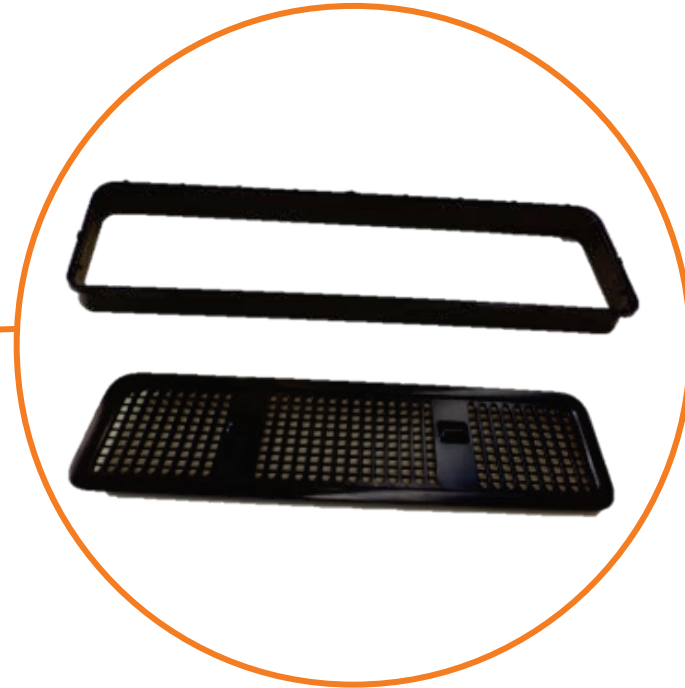

Automotive



Agriculture



Truck



Bus



Design and products



Wellness and SPA



ACCESSORIES COMPONENTS Q2



INJECTION

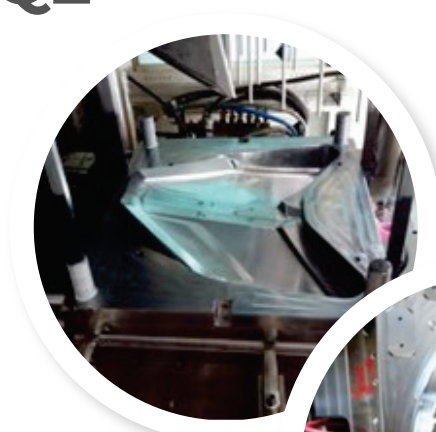

Automotive



Agriculture



Truck



Bus



Design and products



Wellness and SPA



BUMPER REINFORCEMENT

INJECTION

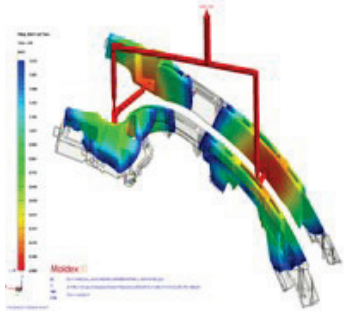
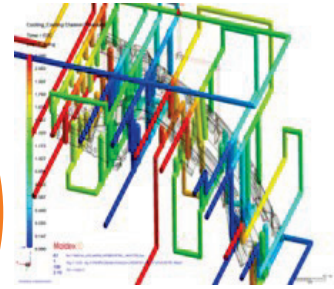

Automotive



Agriculture



Truck



Bus



Design and products



Wellness and SPA



INDUSTRIAL SCRUBBING MACHINE

INJECTION

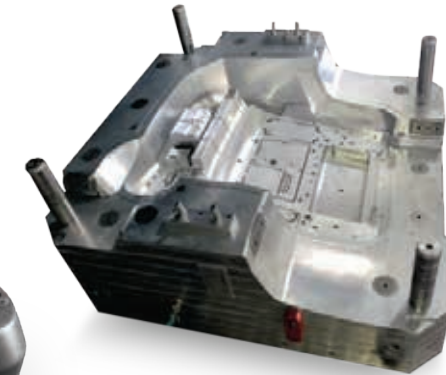
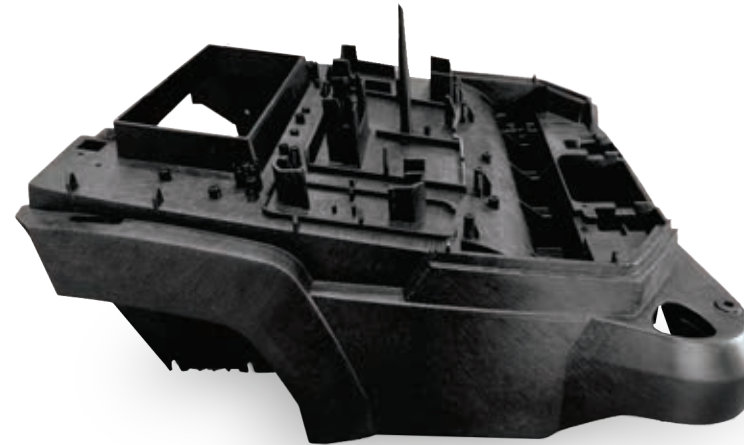

Automotive



Agriculture



Truck

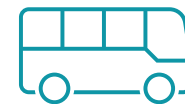

Bus



Design and products



Wellness and SPA



INDUSTRIAL CASE

INJECTION

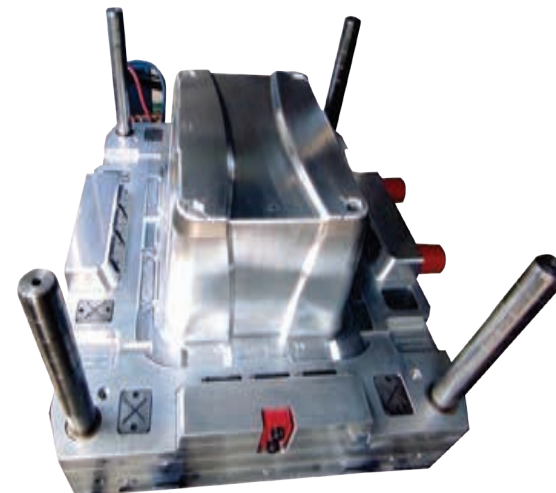

Automotive



Agriculture



Truck



Bus



Design and products



Wellness and SPA



ROOF BOX WITH UNDERCUT

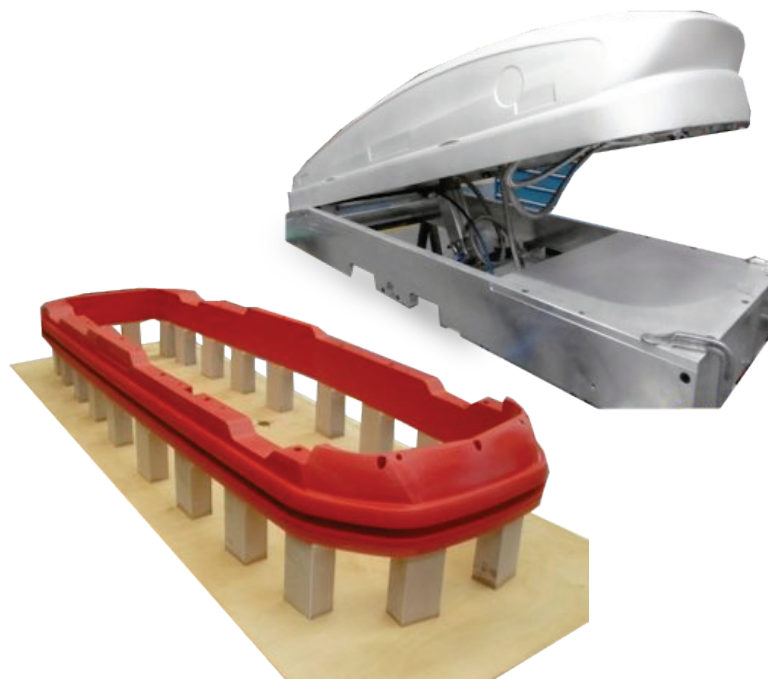

VACUUM FORMING



Automotive



Agriculture



Truck



Bus



Design and products



Wellness and SPA



AUTOMOBILE PARTS

VACUUM FORMING

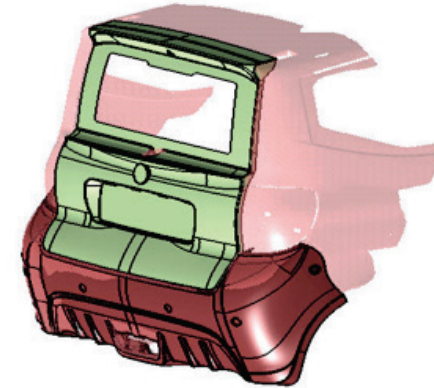

Automotive



Agriculture



Truck



Bus



Design and products



Wellness and SPA



RADIATOR DOOR PANEL

VACUUM FORMING

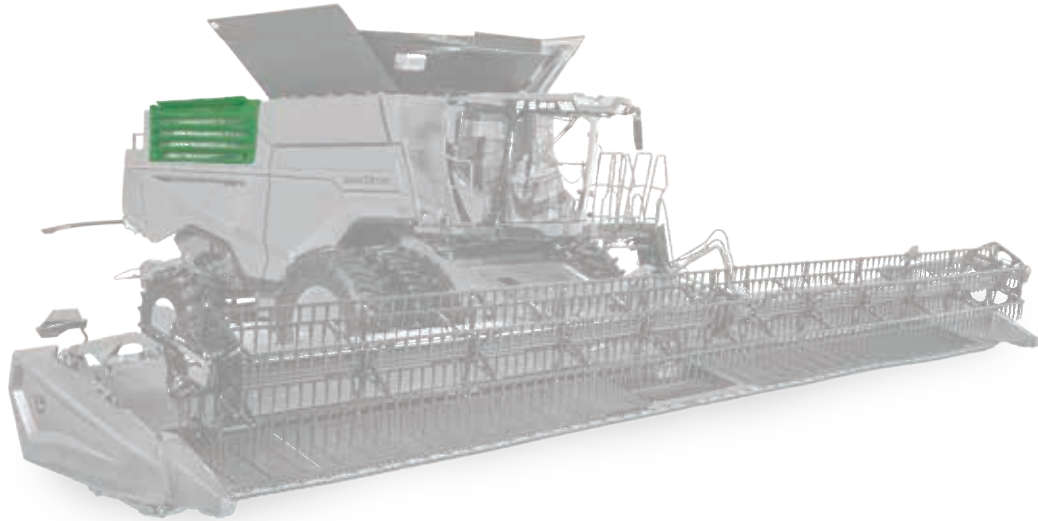

Automotive



Agriculture



Truck



Bus



Design and products



Wellness and SPA



HARVESTER ROOF

VACUUM FORMING



Automotive



Agriculture



Truck



Bus



Design and products



Wellness and SPA



ROUND BAILER

VACUUM FORMING



Automotive



Agriculture



Truck



Bus



Design and products



Wellness and SPA



EXCAVATOR



VACUUM FORMING

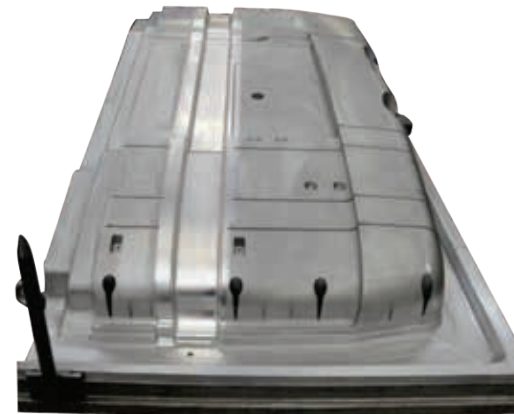

Automotive



Agriculture



Truck



Bus



Design and products



Wellness and SPA



CARAVAN SHOWER BOX



VACUUM FORMING

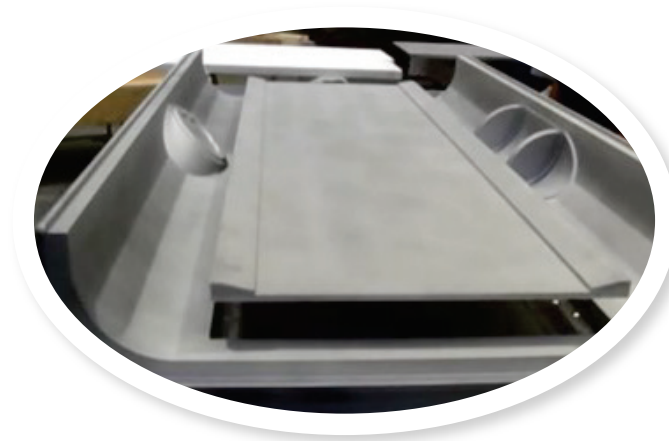

Automotive



Agriculture



Truck



Bus



Design and products



Wellness and SPA



SIDE PANELS FOR TRUCKS



VACUUM FORMING



Automotive



Agriculture



Truck



Bus



Design and products



Wellness and SPA



HOT TUB

VACUUM FORMING

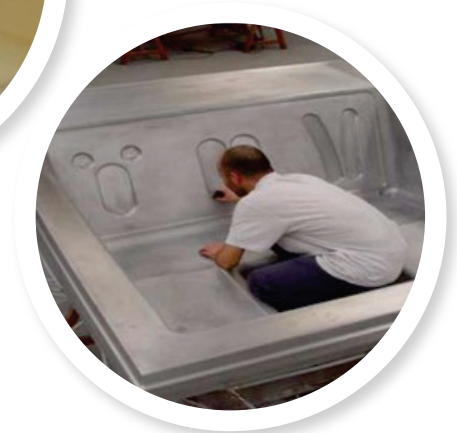
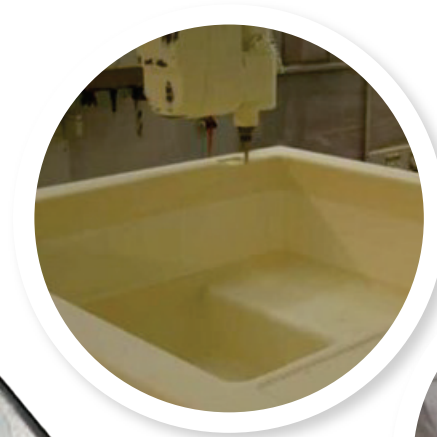
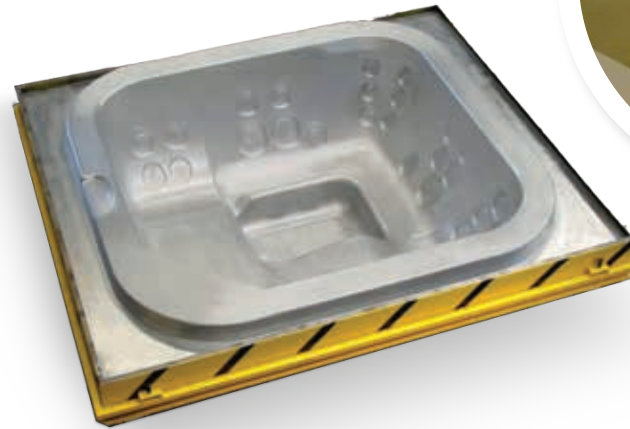

Automotive



Agriculture



Truck



Bus



Design and products



Wellness and SPA



HOT TUB



THERMOFORMING

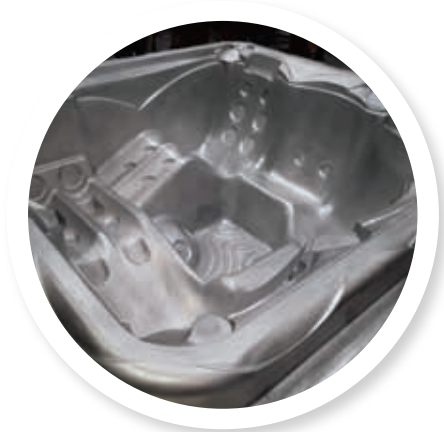

Automotive



Agriculture



Truck



Bus



Design and products



Wellness and SPA



SPRAYER TANKS

ROTOMOULDED



Automotive



Agriculture



Truck



Bus



Design and products



Wellness and SPA



DIESEL TANK

ROTOMOULDING

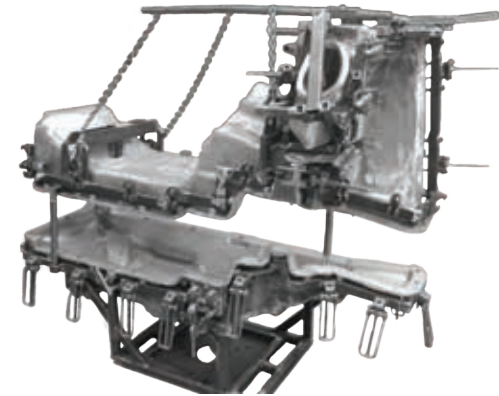

Automotive



Agriculture



Truck



Bus



Design and products



Wellness and SPA



TANK

ROTOMOULDING

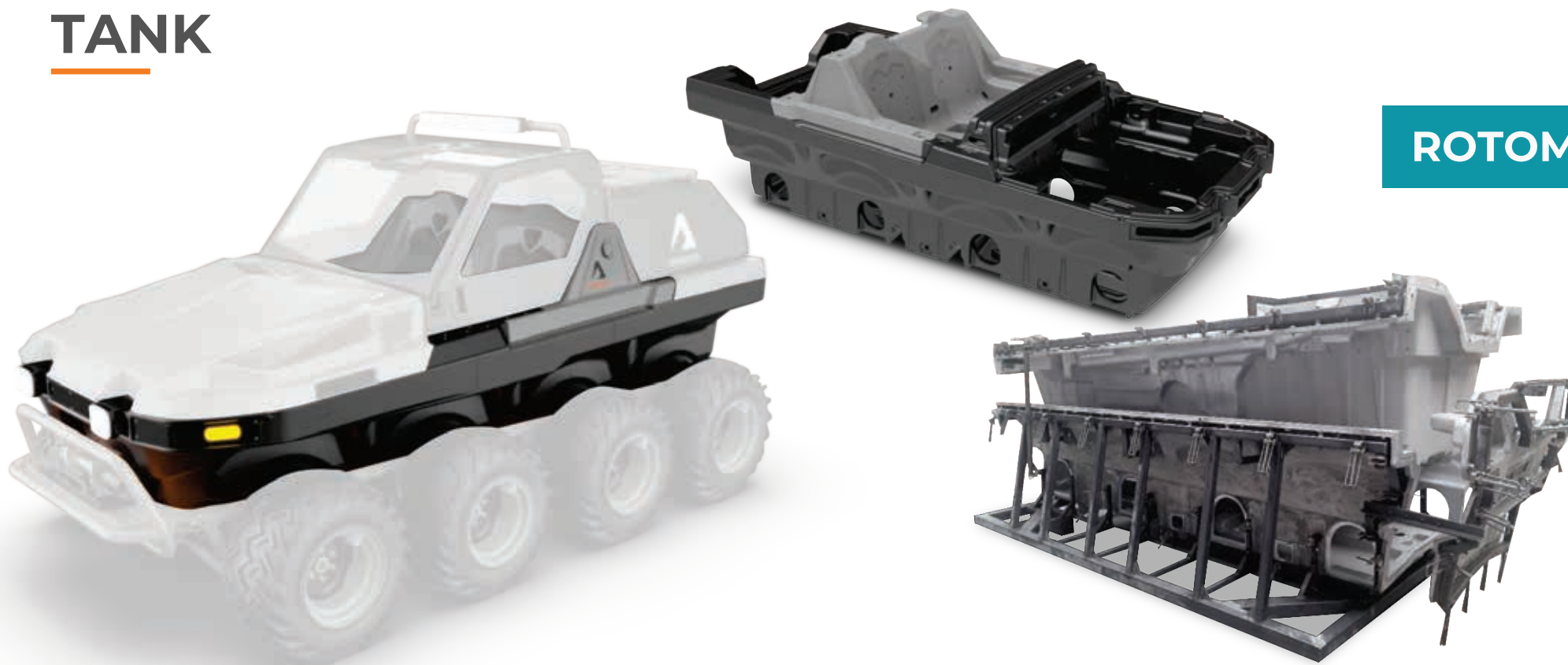

Automotive



Agriculture



Truck



Bus



Design and products



Wellness and SPA



WHEELCHAIR



ROTOMOULDING

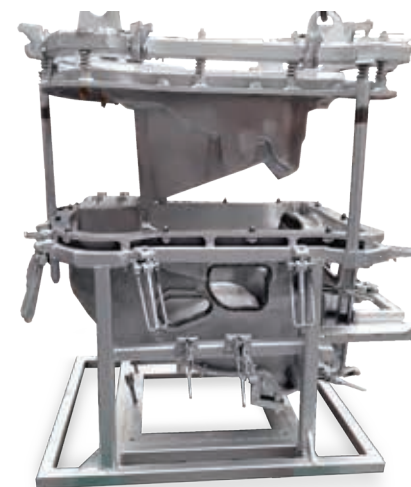

Automotive



Agriculture



Truck



Bus



Design and products



Wellness and SPA



SHIP HULL

ROTOMOULDED



Automotive



Agriculture



Truck



Bus



Design and products



Wellness and SPA



PEDAL-ASSISTED VEHICLE

ROTOMOULDING



Automotive



Agriculture



Truck



Bus



Design and products



Wellness and SPA



HOSPITAL BEDSIDE CABINET

ROTOMOULDING

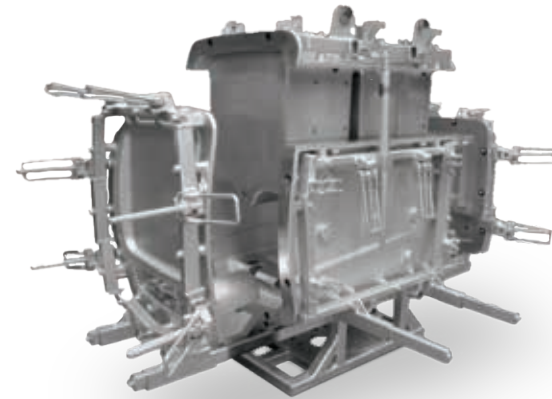

Automotive



Agriculture



Truck



Bus



Design and products



Wellness and SPA



HELLO KITTY & LAMP

ROTOMOULDING

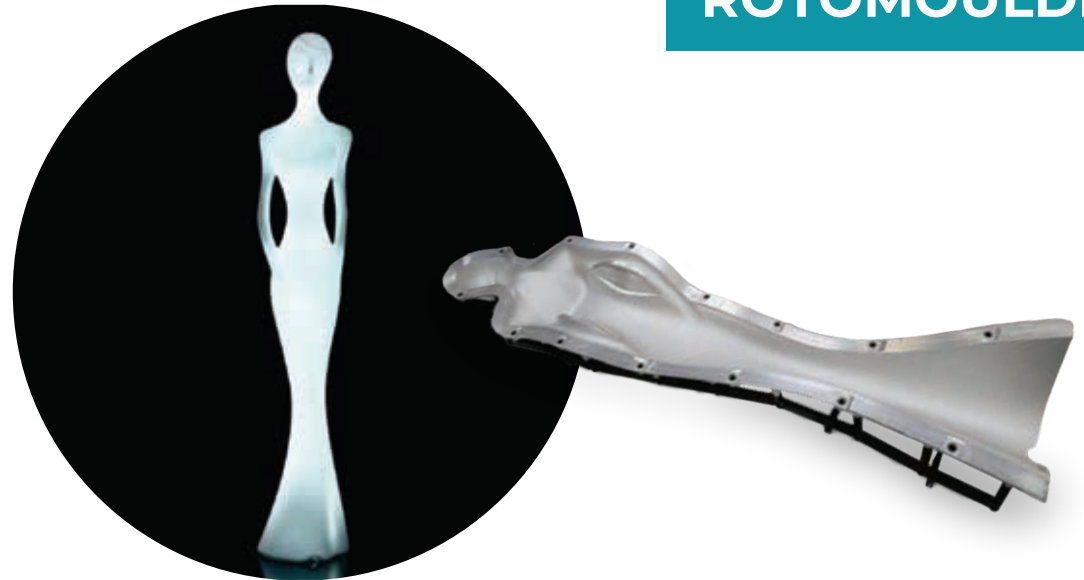
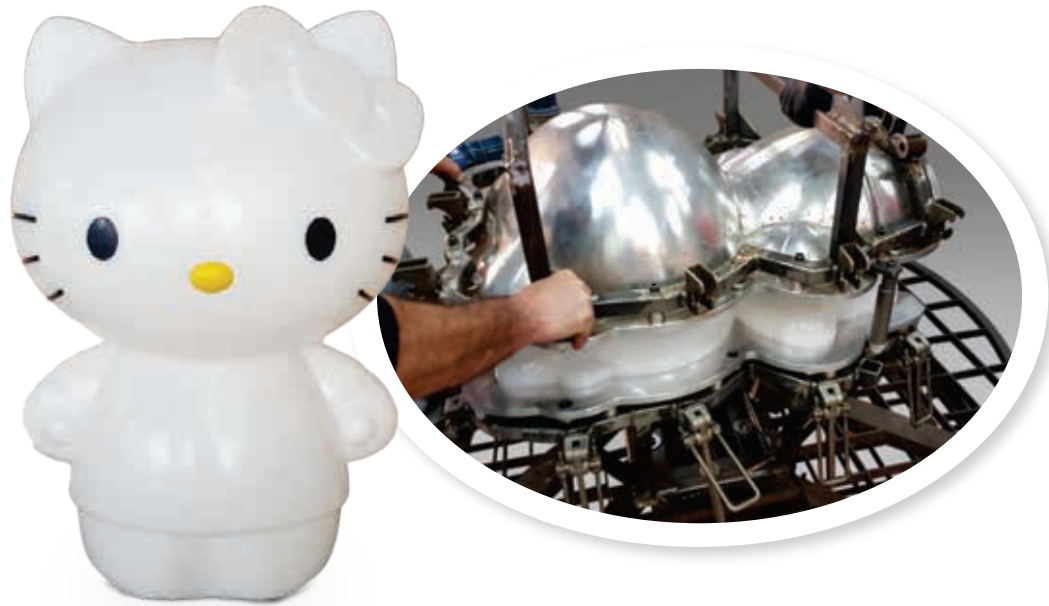

Automotive



Agriculture



Truck



Bus



Design and products



Wellness and SPA



OUTDOOR LIGHTS

ROTOMOULDING



Automotive



Agriculture



Truck



Bus



Design and products



Wellness and SPA



COCKTAIL STATION

ROTOMOULDING



Automotive



Agriculture



Truck



Bus



Design and products



Wellness and SPA



SCRUBBING MACHINE

ROTOMOULDING



Automotive



Agriculture



Truck



Bus



Design and products



Wellness and SPA



SNOW MACHINE



ROTOMOULDING

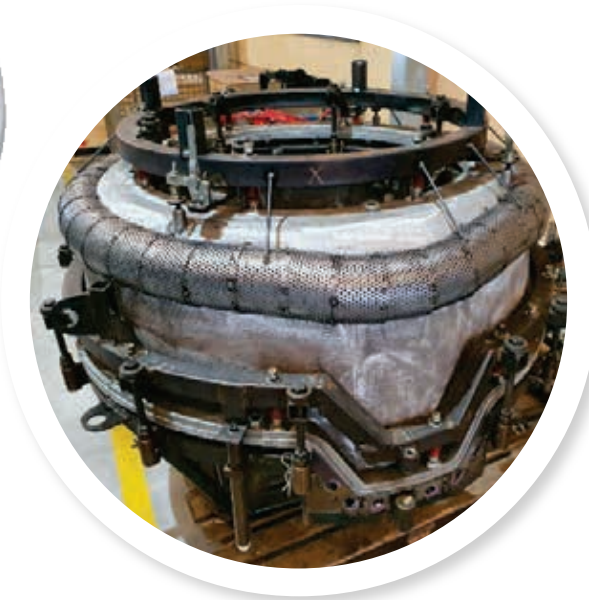

Automotive



Agriculture



Truck



Bus



Design and
products



Wellness and SPA



BOOKCASE

ROTOMOULDED

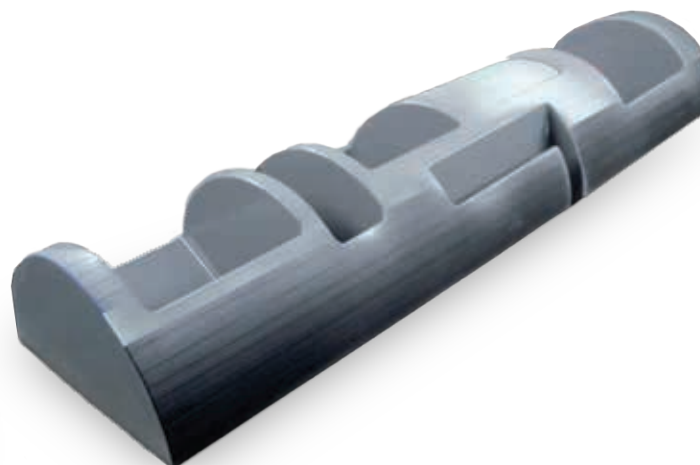

Automotive



Agriculture



Truck



Bus



Design and products



Wellness and SPA



AUTOMOTIVE DASHBOARD



THERMOSETTING
ALUMINIUM MOULDS

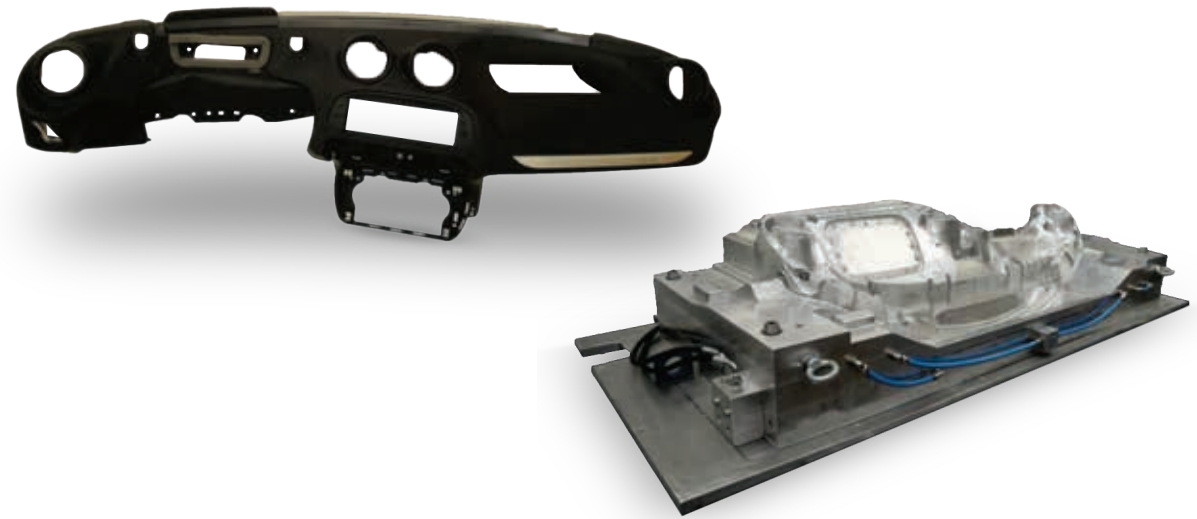

Automotive



Agriculture



Truck



Bus



Design and
products



Wellness and SPA



AUTOMOTIVE FRONT SPOILERS

**THERMOSETTING
ALUMINIUM MOULDS**

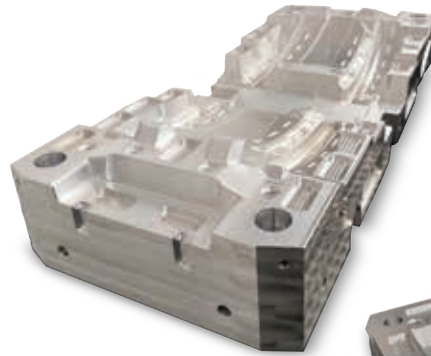

Automotive



Agriculture



Truck



Bus



Design and
products



Wellness and SPA



LAMBORGHINI FRONT BUMPER

**THERMOSETTING
ALUMINIUM MOULDS**

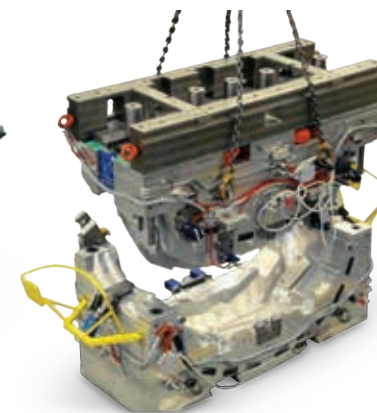

Automotive



Agriculture



Truck



Bus



Design and
products



Wellness and SPA



TRACTOR HOOD

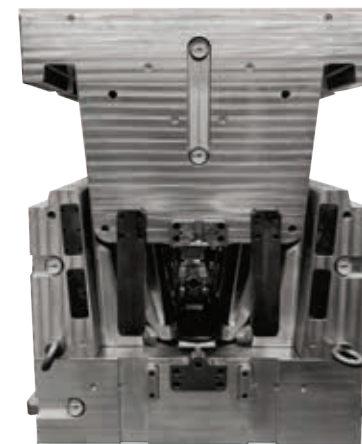

**THERMOSETTING
ALUMINIUM MOULDS**



Automotive



Agriculture



Truck



Bus



Design and
products



Wellness and SPA



TRACTOR HOOD

THERMOSETTING
ALUMINIUM MOULDS

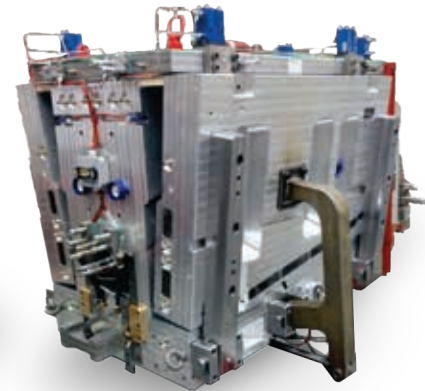

Automotive



Agriculture



Truck



Bus



Design and
products



Wellness and SPA



TRACTOR FLOOR MAT



**THERMOSETTING
ALUMINIUM MOULDS**

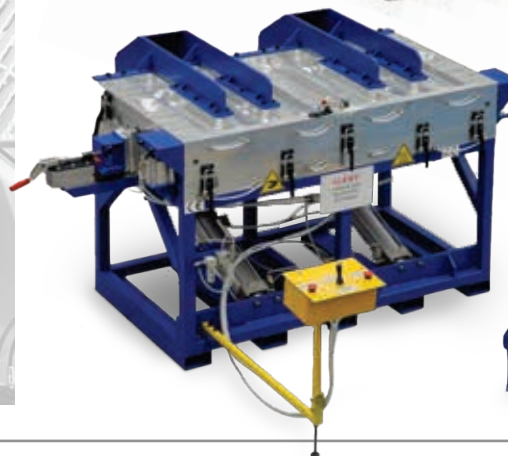

Automotive



Agriculture



Truck



Bus



Design and
products



Wellness and SPA



FENDERS TRACTOR CLASS



**THERMOSETTING
ALUMINIUM MOULDS**



Automotive



Agriculture



Truck



Bus



Design and
products



Wellness and SPA



TRUCK SIDE SKIRT

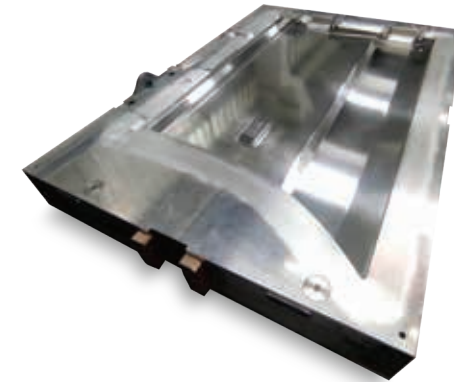
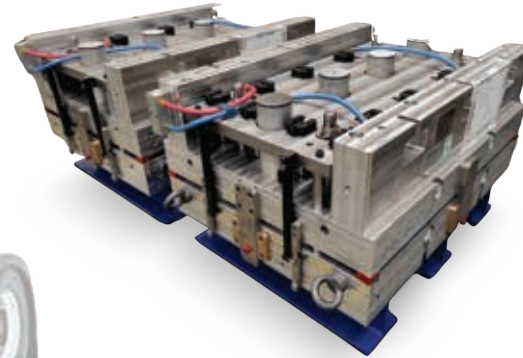

**THERMOSETTING
ALUMINIUM MOULDS**



Automotive



Agriculture



Truck



Bus



Design and
products



Wellness and SPA



UPS FRONT TRUCK

THERMOSETTING ALUMINIUM MOULDS



Automotive



Agriculture



Truck



Bus



Design and products



Wellness and SPA



TRUCK ROOF SPOILER



THERMOSETTING ALUMINIUM MOULDS

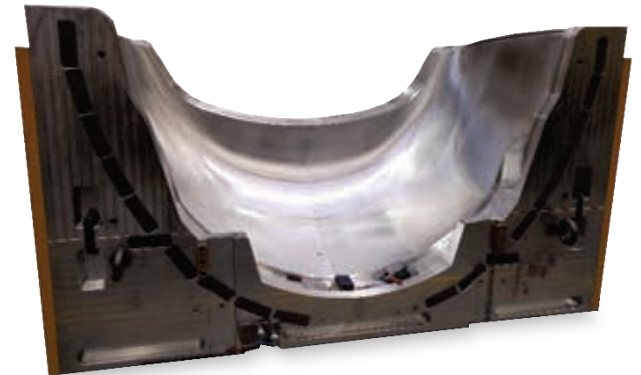

Automotive



Agriculture



Truck



Bus



Design and products



Wellness and SPA



SIDE PANELS CITY BUSES



**THERMOSETTING
ALUMINIUM MOULDS**



Automotive



Agriculture



Truck



Bus



Design and
products



Wellness and SPA



BATTERY COVER



**THERMOSETTING
STEEL MOULDS**



Automotive



Agriculture



Truck



Bus



Design and
products



Wellness and SPA



BATTERY COVER

THERMOSETTING
STEEL MOULDS

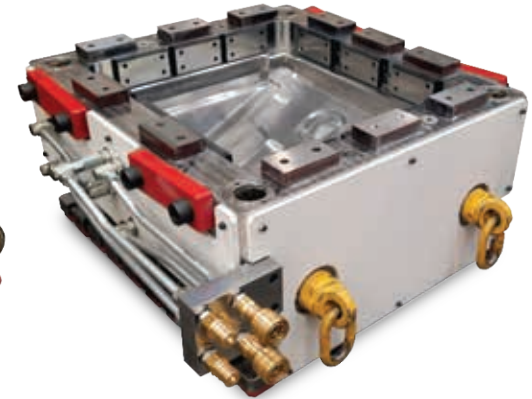
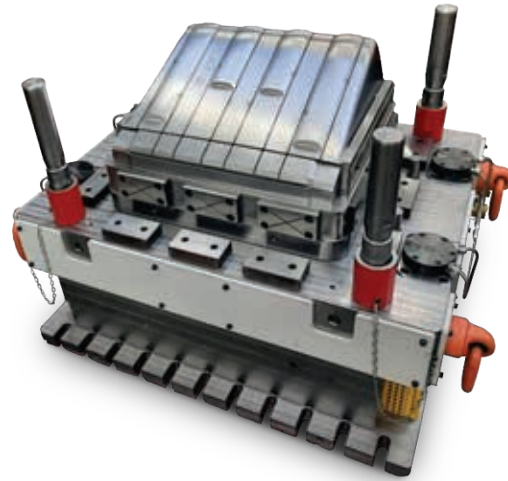

Automotive



Agriculture



Truck



Bus



Design and
products



Wellness and SPA



RADIATOR PANEL

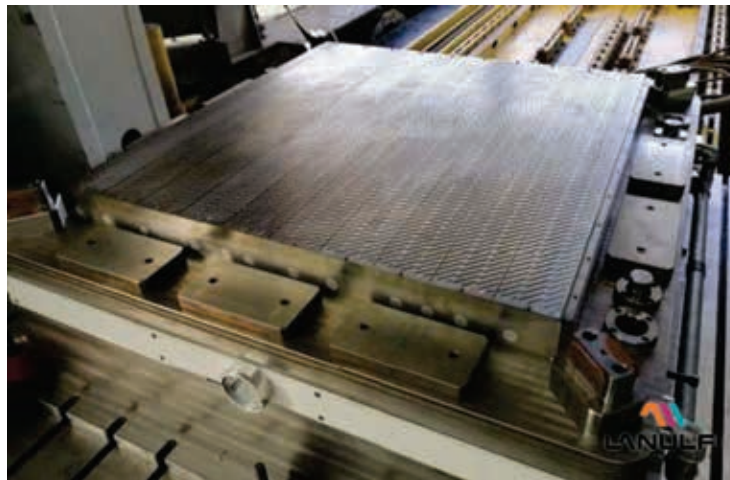

**THERMOSETTING
STEEL MOULDS**

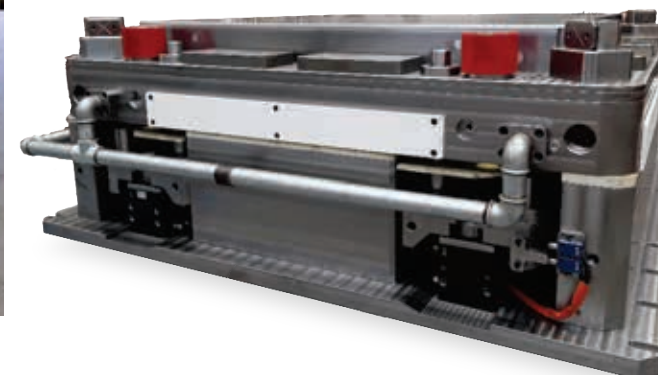

Automotive



Agriculture



Truck



Bus



Design and
products



Wellness and SPA



AUTOMOTIVE MOCKUP 1:1

MODELS AND
PROTOTYPE



Automotive



Agriculture



Truck



Bus



Design and
products



Wellness and SPA



CARAVAN MOCKUP 1:1



MODELS AND
PROTOTYPE



Automotive



Agriculture



Truck



Bus



Design and
products



Wellness and SPA





AUTOMOTIVE MOCKUP 1:1

MODELS AND PROTOTYPES



Automotive



Agriculture



Truck



Bus



Design and products



Wellness and SPA



MOCKUP

MODELS AND PROTOTYPES



Automotive



Agriculture



Truck



Bus



Design and products



Wellness and SPA



STATUES AND SCULPTURES



MODELS AND
PROTOTYPES



Automotive



Agriculture



Truck



Bus



Design and
products



Wellness and SPA



WELLNESS HOT TUBS

MODELS AND PROTOTYPES

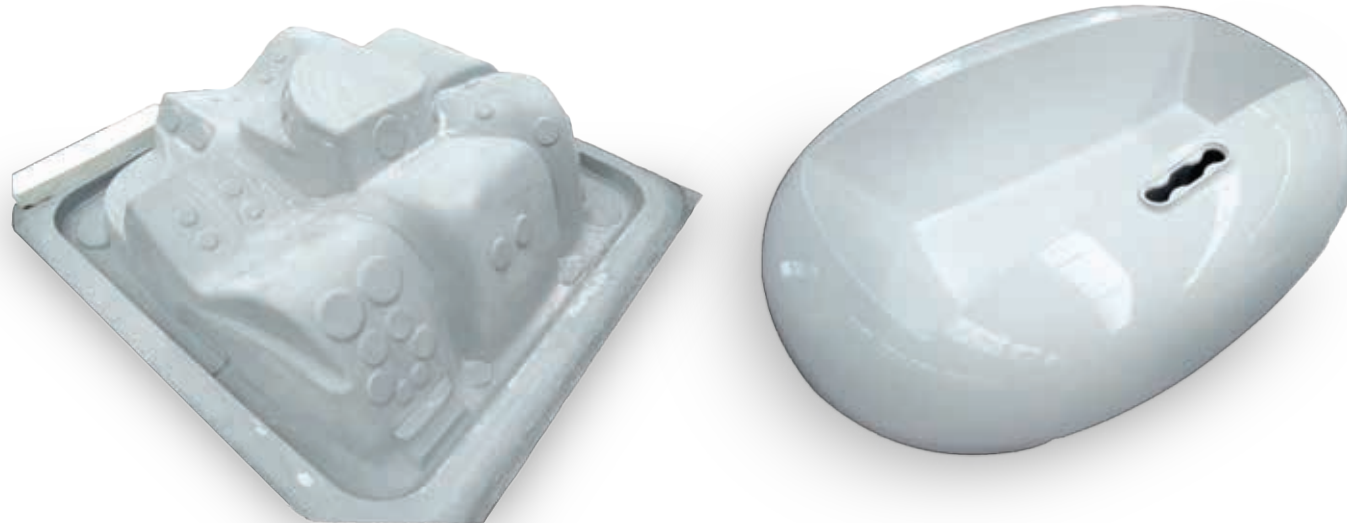

Automotive



Agriculture



Truck



Bus



Design and products



Wellness and SPA



CONTROL JIGS

SPECIAL EQUIPMENTS

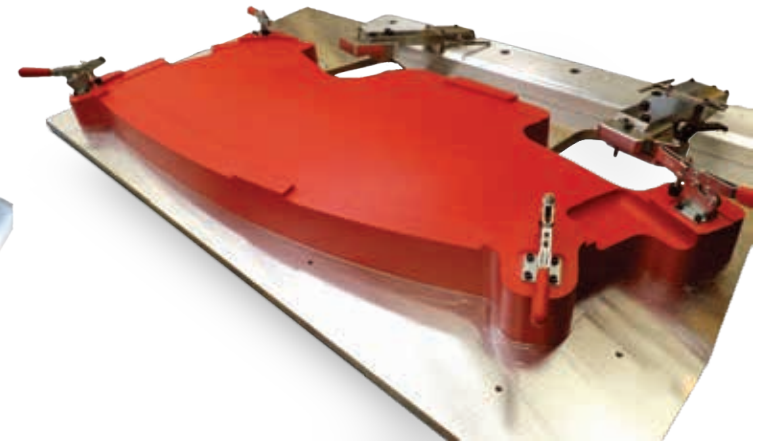
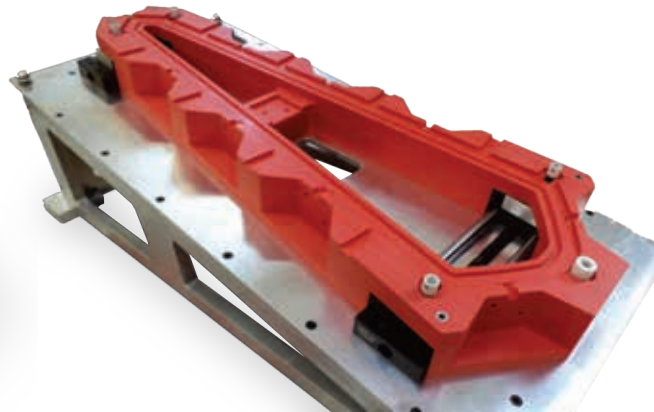

Automotive



Agriculture



Truck



Bus



Design and products



Wellness and SPA



CONTROL JIGS

SPECIAL EQUIPMENTS

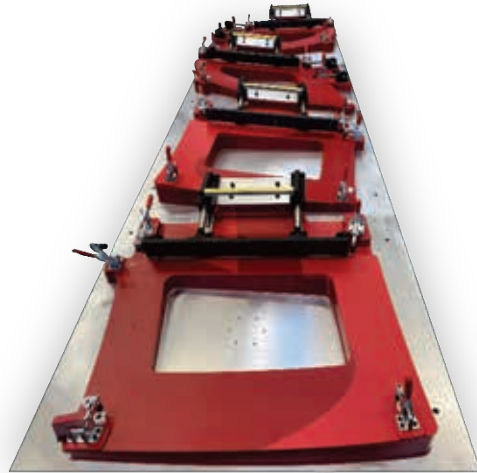
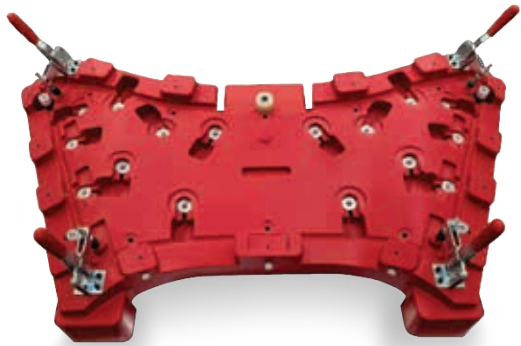

Automotive



Agriculture



Truck



Bus



Design and products



Wellness and SPA



WATER JET CUTTING JIGS

SPECIAL EQUIPMENTS

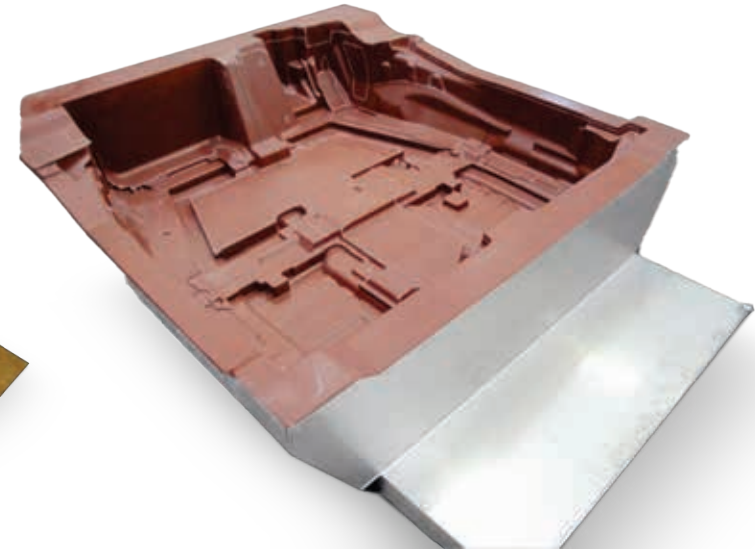
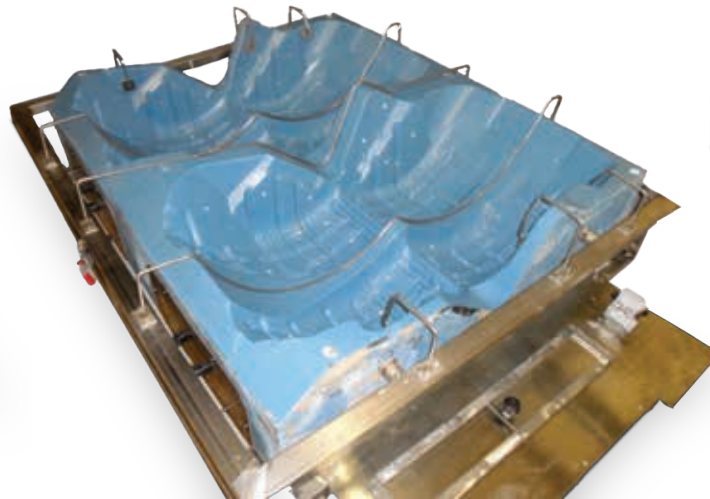

Automotive



Agriculture



Truck



Bus



Design and products



Wellness and SPA



CONTROL JIGS

SPECIAL EQUIPMENTS

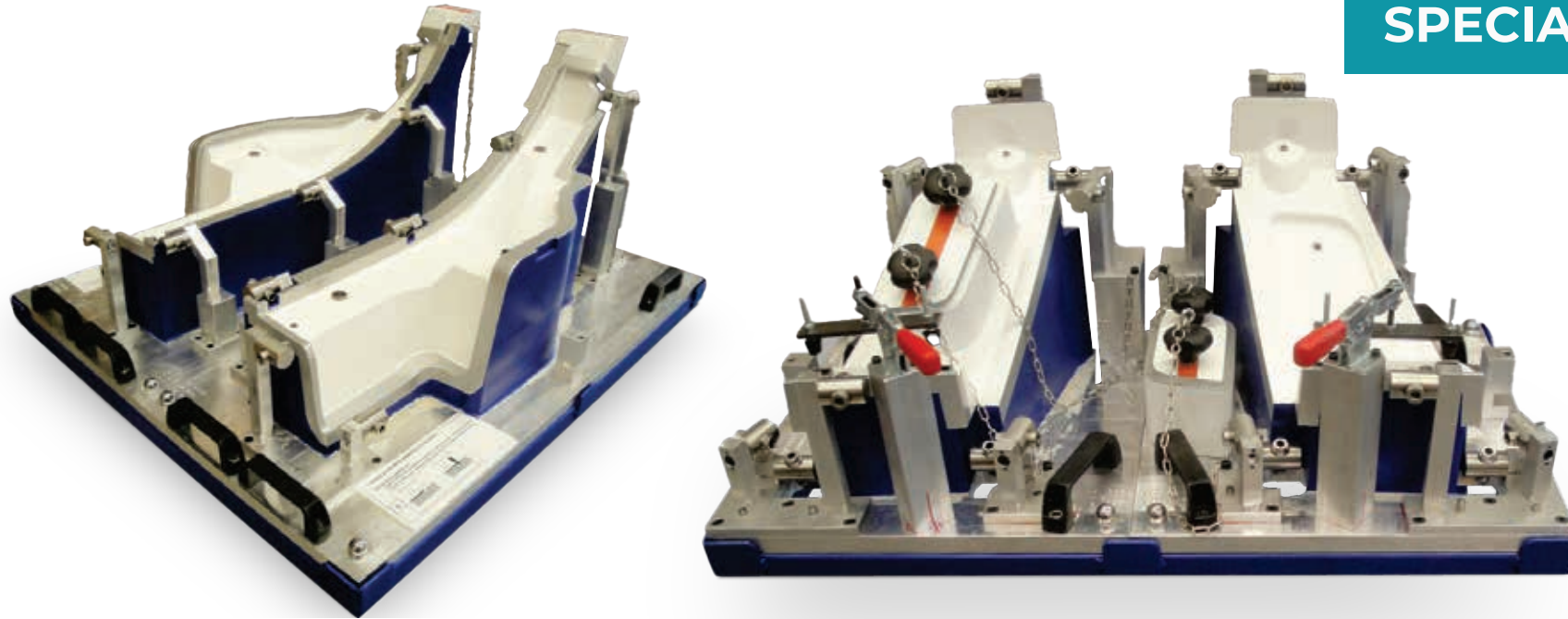

Automotive



Agriculture



Truck



Bus



Design and
products



Wellness and SPA



CONTROL JIGS

SPECIAL EQUIPMENTS



Automotive



Agriculture



Truck



Bus



Design and products



Wellness and SPA



GLUING JIGS

SPECIAL EQUIPMENTS



Automotive



Agriculture



Truck



Bus



Design and
products



Wellness and SPA



Strategic goals

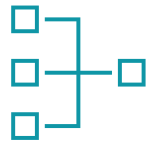

Mapping and digitization of business processes

The process will consist of three phases:

1. Identifying and shaping the processes
2. Analyzing where improvements can be made
3. Determining the digitization level of the flows

The activity will be led by the production manager.

Estimated investment for this project: 80k €.



External growth

Promotion of scouting activities to identify, with an acquisition view, an existing production entity or the creation of a third Lanulfi production site in Eastern Europe.



Revenue, EBITDA, market share

Aiming at a total revenue of more than 10mln € and an EBITDA of 1.1mln €
Europe market share equal to:
2% aluminum molds and 0.06% steel molds.



Strategic goals



Recruiting, training and staff retention

Responding to critical issues in staff recruitment and retention.
Estimated investment for this project in the three-year period 2023/2025: 250k €.

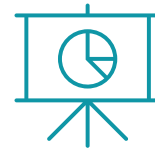

Increase production capacity Steel and Moulds

Highlighting specific marketing and sales activities that support growth to achieve the set targets (turnover, margins, market share). Investments in new machinery for both steel and aluminum are also considered important.
Estimated investment for this project: 2.5mln €.



Moulds and Steel Fusion

Merging of Lanulfi Moulds and Lanulfi Steel aimed at giving Steel more prominence in the domestic and international markets.



Technology and equipment



WORKING CENTER FOR MODELS

- C.M.S. POSEIDON 38/90: continuous 5 axes - strokes: 9000x4000x2000
- C.M.S. POSEIDON 20/48: 5 continuous axes- strokes: 4800x2000x1300

OVERHEAD CRANES

- Overhead crane 5 tons capacity



WORKING CENTER FOR ALUMINUM

- FTP Dino X: 5 continuous axes - strokes: 4500x3500x1500
- FTP Stinger 280: 5 continuous axes - strokes: 2000x1400x800 with 5 pallets
- PROMAC SHARAV: 5 continuous axes - strokes: 4500x2500x1200
- PROMAC SHARAV: 5 continuous axes - strokes: 3500x4000x1200
- PROMAC ZEPHYR: 5 continuous axes - strokes: 2300x1600x1000
- FPT LEM 936: 5 indexed axes - strokes: 2600x1200x2000
- EMCO MMV 2000: 5 continuous axes - strokes: 2000x800x750
- POLISHING ROBOT: Roboticom-ABB IRB - 7 axes - reach: R 3700 mm
- CANNON/TCS: 2000x2000x2000 - Machine for assembly

OVERHEAD CRANES

- Overhead crane 10 tons capacity
- Overhead crane 6,3 tons capacity



PROCESSING MACHINERY

MILLING MACHINES:

- MECOF Linearmill 2200 - 5 continuous axes - strokes: 4000x2200x1000
- MECOF Agile CS 500 – 3 axes – strokes: 4000x1000x1800
- ALESAMONTI FT30 – 3 axes - strokes: 3000x1200x1500
- PARPAS 16 – 3 axes - strokes: 1600x800x800
- FAMU FAS 1M – 3 axes - strokes: 600x450x400

DRILLS: 2 drills with maximum drill 1600x60

GRINDERS: 2 grinding machines

OVERHEAD CRANES

- Overhead crane 20 tons capacity
- Overhead crane 10 tons capacity



“Coming together is a beginning
keeping together is progress
working together is success”

- *Henry Ford*

